

Global Sales Network



Vacancies for valuable distributors / agents in certain countries are available.

L&W MACHINE TOOLS, INC.

Factory: No. 53 Ho Tso St., Feng Yuan District, Taichung City, Taiwan
Export Office: 9F-8, No. 62, Ta Ya Road, Taichung, Taiwan
Tel: +886-4-2201-4701 Fax: +886-4-2203-6013
<http://www.lw-machinetools.com> E-mail: lwmachin@ms31.hinet.net



FB SERIES FLAT BED CNC PRECISION TURNING CENTER

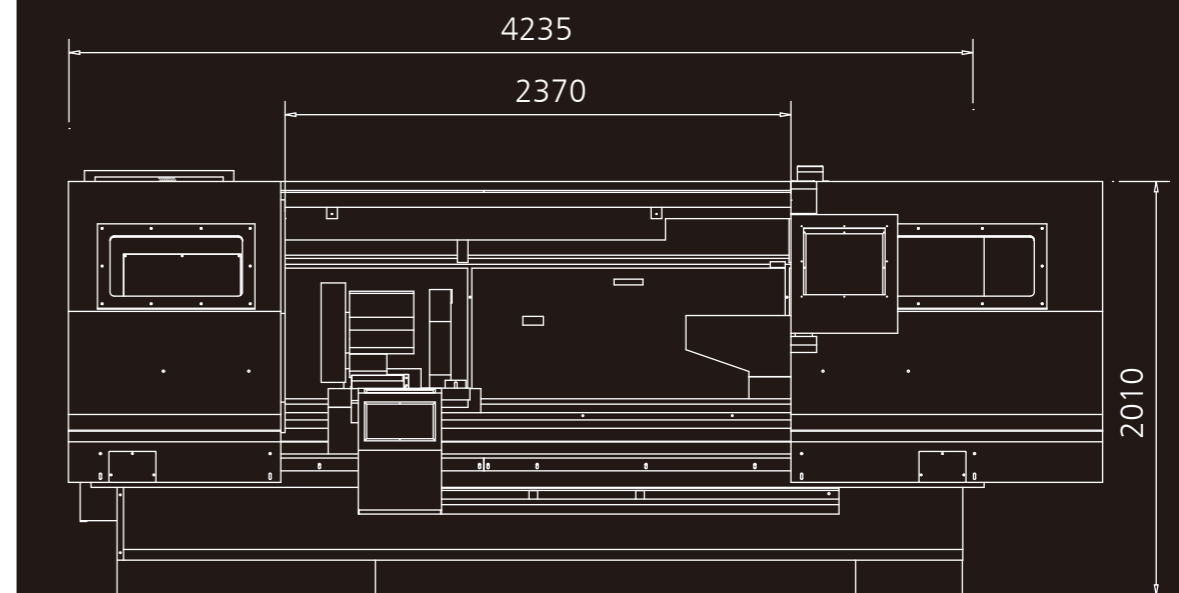

Complete Product Lineup



The CYCLONE FB series CNC precision turning centers are general purpose, highly cost-effective machines with large capacity, high accuracy, rigid structure with a wide choice of models.

Easy operation



High stock
removal rate



Accuracy



Unbeatable price



Swing Over Bed: 460 ~ 1600 mm.

Z Axis Stroke: 810 ~ 6000 mm.

X Axis Stroke: 280 ~ 830 mm.

FB-18 / 21 / 25 SERIES

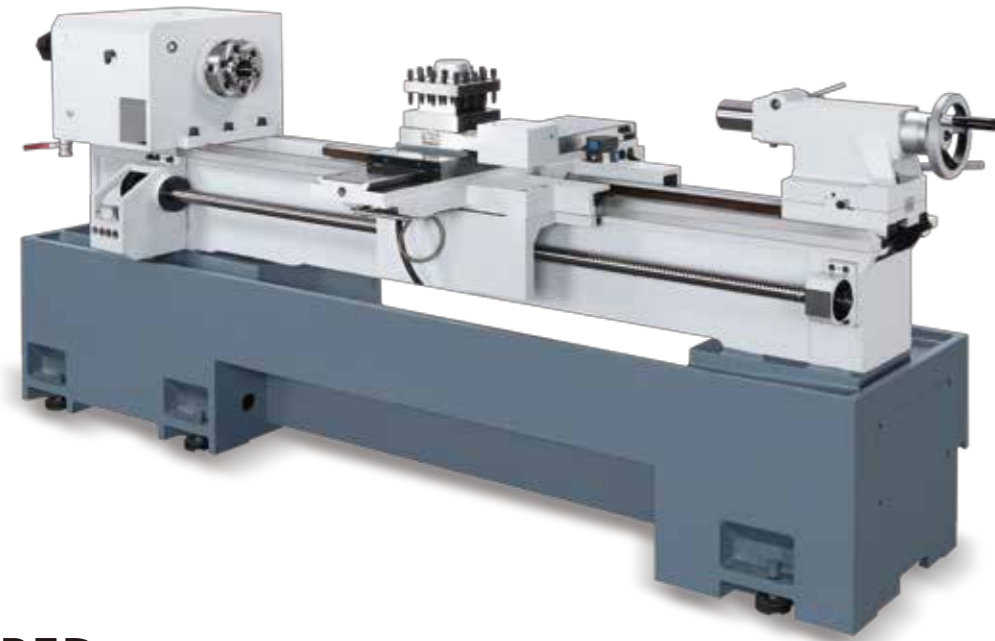

BED

The bed and stand are made of one-piece Meehanite cast iron, which is annealed treatment to eliminate internal residual stress and more stable that can be resisted to vibration due to deep cutting.

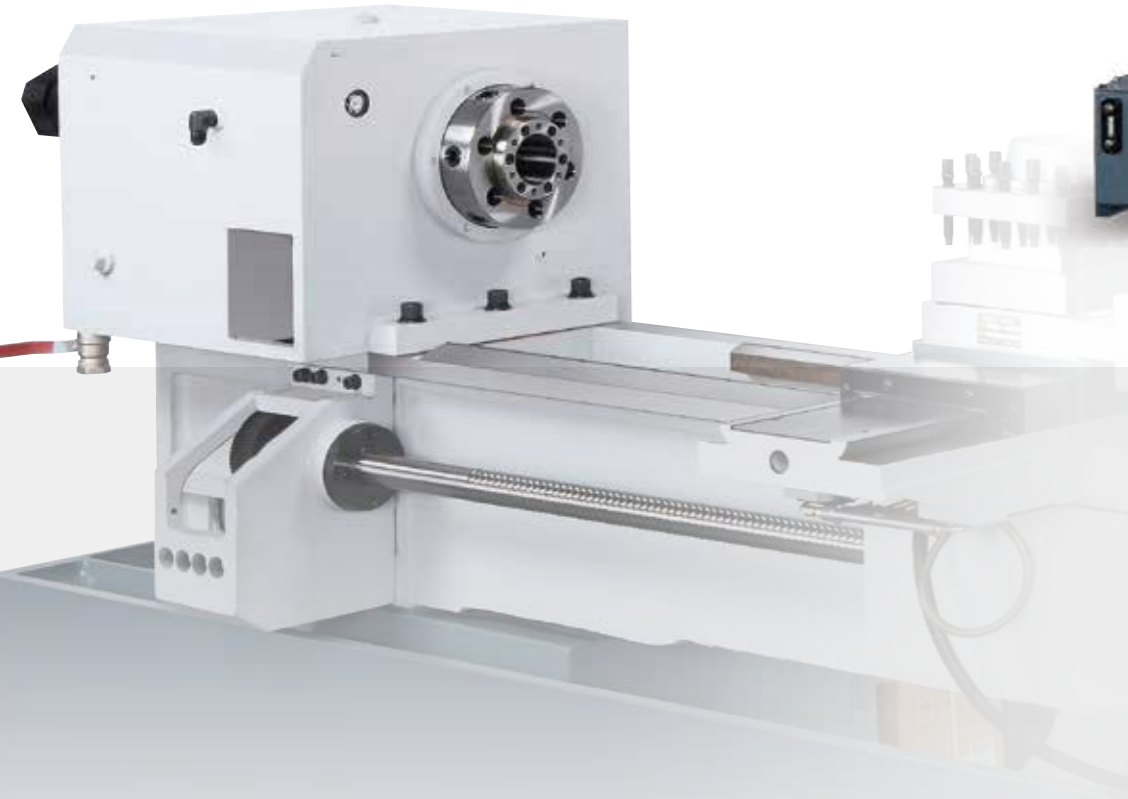

MANUAL TAILSTOCK

Rigidly constructed tailstock is able to facilitate making precision turning and drilling. Tailstock quill is hardened and precision ground.



FB-26 / 30 / 33 SERIES



EXTRA WIDE BED

The extended bed and stand are made of one-piece Meehanite cast iron, featuring excellent damping coefficient for heavy duty cutting. The extra wide slide ways pitch is 450 mm. that ensures steady motion control for axes.



MANUAL TAILSTOCK

The heavy duty cast tailstock features a hardened and ground quill; it provides easy movement for precision cutting and drilling capability while maintaining high rigidity for part support.

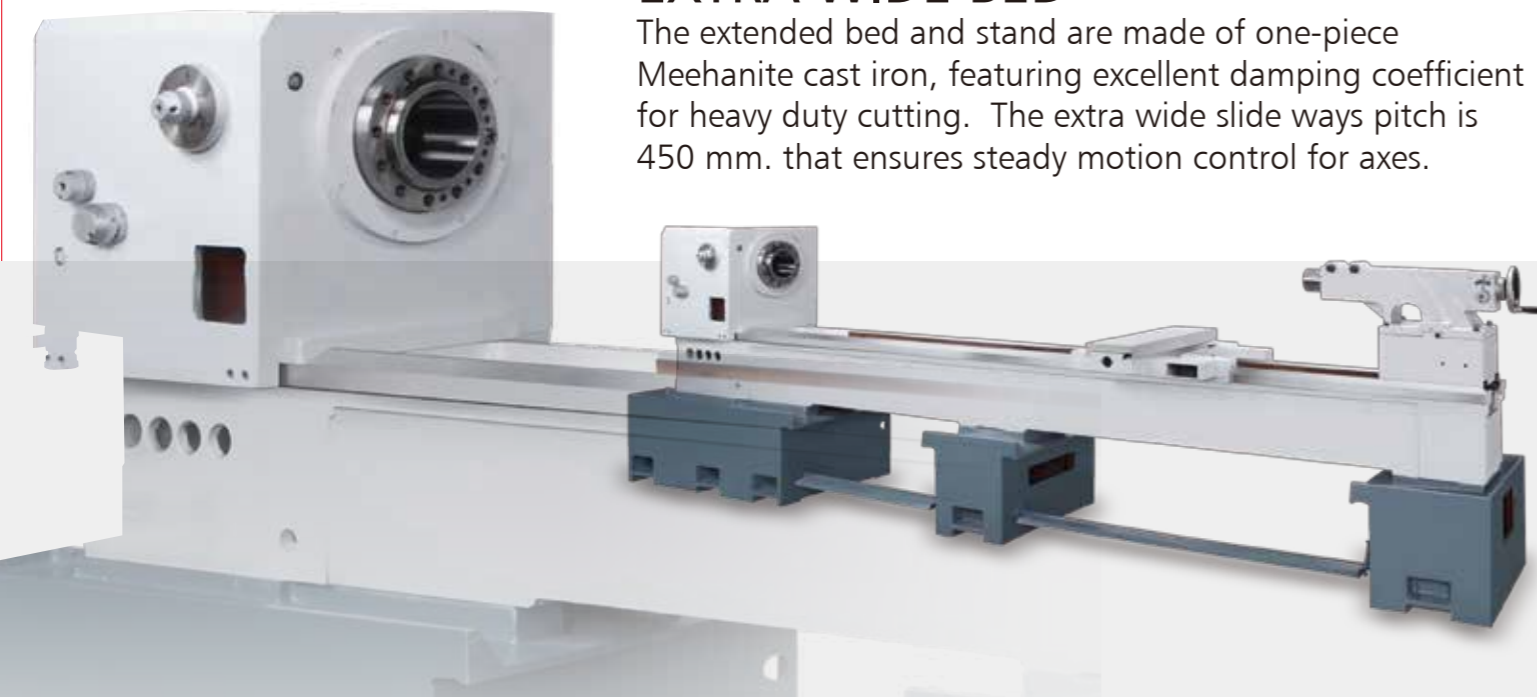

GENERAL FEATURES



CONTROL SYSTEM

The FB series machines are equipped with FAGOR 8055i Controller. The powerful arithmetic capability features stable performance as well as user-friendly man-machine interface (MMI). FANUC and SIEMENS controllers are available on request.



ELECTRICAL CABINET

Wires, cables and all pipes inside the electrical cabinet are well organized with clear wire numbers and labels. The easy-to-maintain cabinet is fitted with standard heat exchanger to stabilize the electrical components' performance, and to extend their service life time.



QUALITY INSPECTION

FB Series lathes are all strictly inspected by complete quality assurance procedures, including spindle temperature rising test, geometric accuracy inspection, laser backlash compensation and practical cutting test.



HEADSTOCK

The spindle and gears used in the headstock are made of CR-MO materials, which has been heat treated to Rockwell HRC-60° with a high precision ground finish.

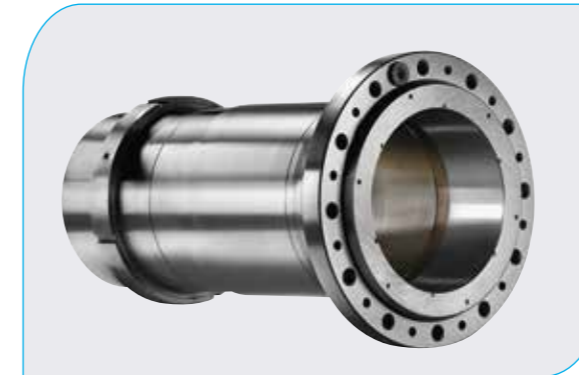

SPINDLE

The spindle is powered via a 3-step gear assembly that features high torque output especially during low speed range. In combination with high efficient lubrication system, the spindle assembly is low noise, low vibration and low temperature rising.



OUTLINE DESIGN

The square / rectangular sheet metal and wide door width features extra large machining area that minimizes structural interference and optimizes workpieces' accessibility. The cutting chips and fluid can be conveyed to the outside of machine efficiently. The sturdy machine saddle ensures high machining accuracy especially for heavy duty cutting.



VERSATILE APRON CONTROLS

Specially designed hand-wheels with simultaneous movement of both X and Z axes and adjustable resolutions available. CNC can be shifted left or right hand side

OPTIONS



BI-DIRECTIONAL ELECTRIC 4-WAY TOOL POST

The unique turret can tolerate heavy cutting and maintain indexing repeatability of 0.003 mm. The turret will automatically change tools while using the CNC control features to adjust the spindle speed to match the tool.

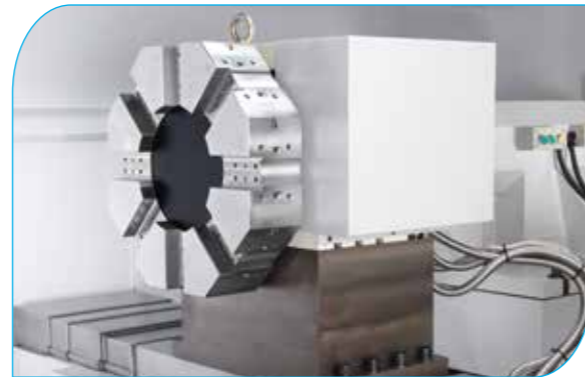

8-POSITION HYDRAULIC TURRET

High efficiency high power hydraulic turret features accurate performance with long term stability.



4-JAW INDEPENDENT CHUCK

The 4-jaw independent chuck is suitable for holding various irregular shaped working pieces. Each jaw is adjusted independently. The 4 jaws can be reversed to grip the inside or outside of the working piece. Chuck diameter is available for each FB model.



3-JAW SCROLL CHUCK (FRONT AND REAR)

The 3-jaws move in and out together for quick clamping a working piece. Chuck diameter is available for each FB model



SAUTER ELECTRICAL TURRET (VDI 30 / VDI 40)



HYDRAULIC TANK

Air-cooling hydraulic unit powers the hydraulic chuck and the turret with extremely high reliability.



CHIP CONVEYOR

High performance chip conveyor removes the chips as well as the cutting heat away from the working area, ensures job efficiency and stability.



STEADY REST

The steady rest is applied for supporting a long working piece, to prevent the working piece from springing or bending. Jaws are adjustable to hold the working piece in the correct position.



FOLLOW REST

The follow rest is mounted to the saddle and moving together with it in order to prevent the working piece springing away from the point of cutting tool.



HIGH PRESSURE COOLANT PUMP

High pressure coolant pump stabilizes cutting accuracy, improves workpiece surface finishes and also extends turning tool's life time.



3-JAW POWER CHUCK

Well-balanced power chuck displays extraordinary capacity that features low vibration, low noise and low temperature-rising.



TIMKEN BEARING

Timken Bearings are employed on L&W FB series machines which spindle bore is larger than 9", featuring high accuracy, high rigidity and low vibration.



OIL COOLER

Power Charts of Inverter Motors

— Torque Nm
- - - Power

FB-18 Series (3100 rpm)
Spindle Bore 56 mm, Motor: 7.5HP

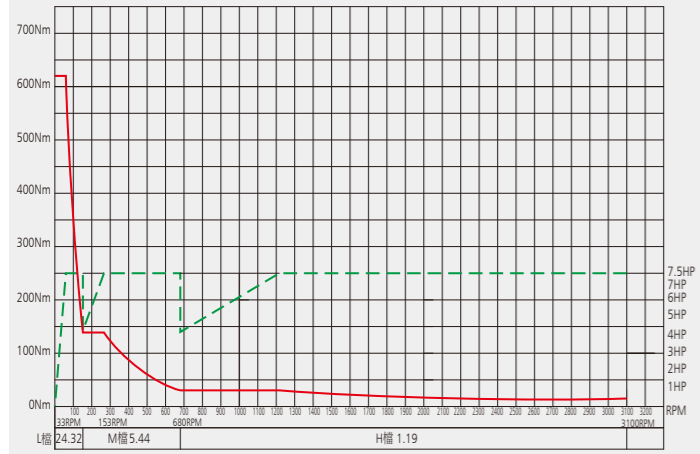

FB-21 / 25 / 26 Series (2250 rpm)
Spindle Bore 85 mm, Motor: 15HP

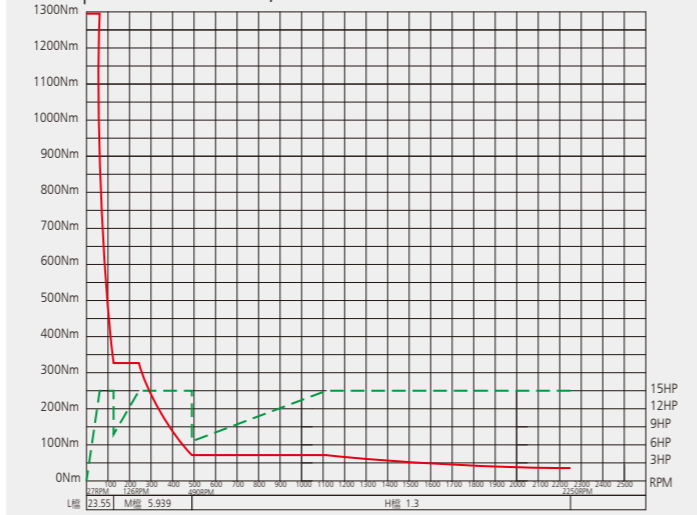

FB-21 / 25 / 26 / 30 / 33 Series (1500 rpm)
Spindle Bore 105 mm, Motor: 15HP

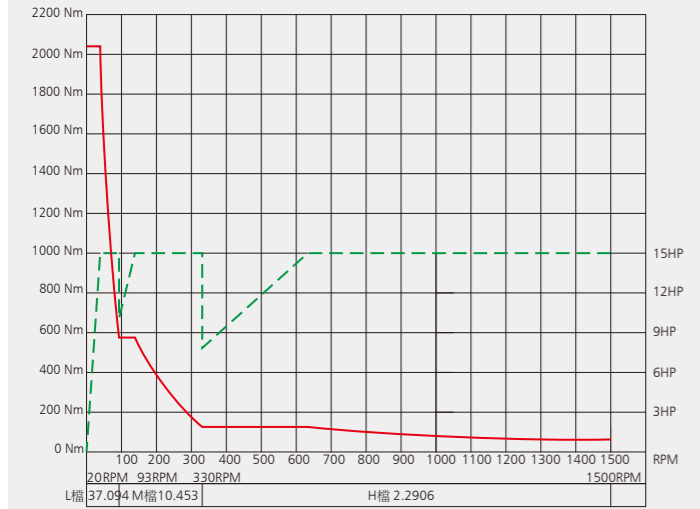

FB-21 / 25 / 26 / 30 / 33 Series (1500 rpm)
Spindle Bore 105 mm, Motor: 20HP

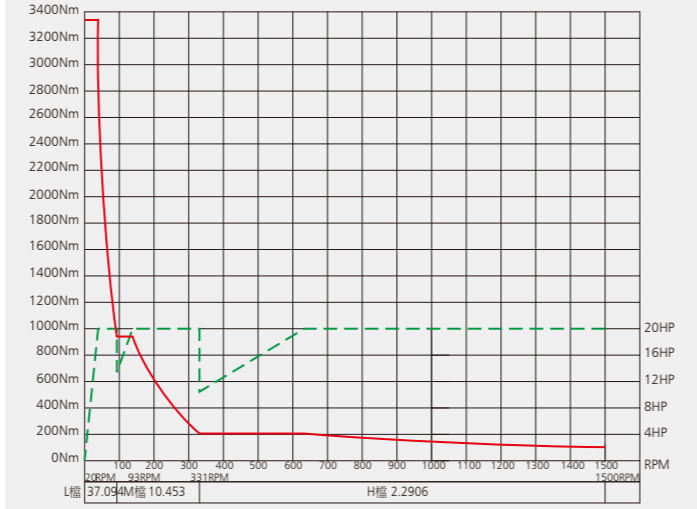

FB-25 / 26 / 30 / 33 Series (800 rpm)
Spindle Bore 155 mm, Motor: 20HP

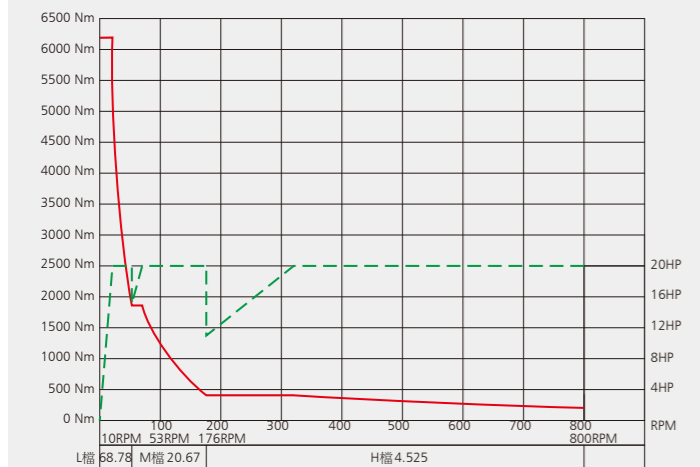

Power Charts of Servo Motors

FB-18 Series
Spindle Bore 56 mm, Motor: FM7-A075 47.7 Nm 7.5/11 Kw

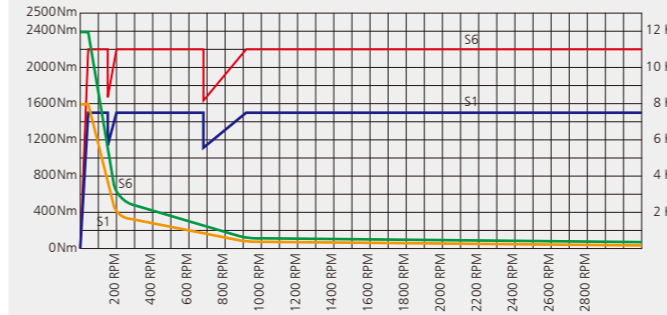

FB-21 / 25 / 26 Series
Spindle Bore 85 mm, Motor: FM7-A110 70 Nm 11/15.5 Kw

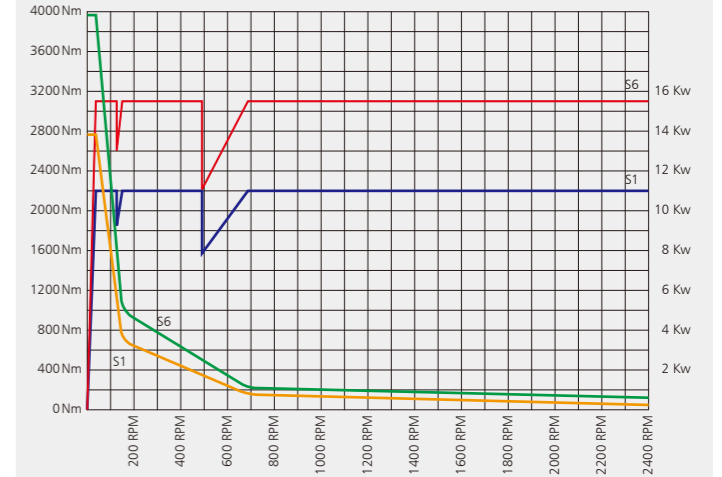

FB-21 / 25 / 26 / 30 / 33 Series
Spindle Bore 105 mm, Motor: FM7-A150 95.5 Nm 15/22 Kw

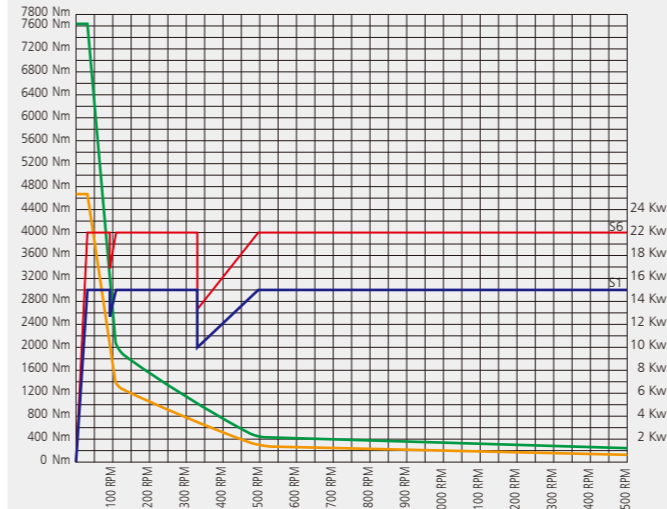

FB-25 / 26 / 30 / 33 Series
Spindle Bore 155 mm, Motor: FM7-A150 95.5 Nm 15/22 Kw

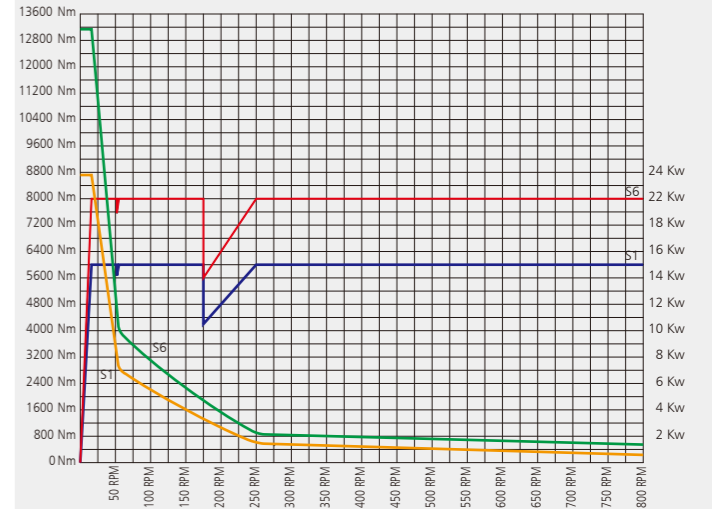

SPECIFICATIONS:

Description / Model	FB-1840	FB-1860	FB-1880	FB-2140	FB-2160	FB-2180	FB-2540	FB-2560	FB-2580			
WORKING CAPACITY												
Swing over bed	460 mm			540 mm			630 mm					
Center height	230 mm			270 mm			315 mm					
Swing over cross slide	230 mm			310 mm			400 mm					
Distance between center	1000 mm	1500 mm	2000 mm	1000 mm	1500 mm	2000 mm	1000 mm	1500 mm	2000 mm			
Width of bed	350 mm			350 mm			350 mm					
HEADSTOCK												
Spindle speed	H: 3100~681 rpm			H: 2250~491 rpm			H: 1500~331 rpm			H: 800~176 rpm		
	M: 680~153 rpm			M: 490~126 rpm			M: 330~93 rpm			M: 175~53 rpm		
	L: 152~33 rpm			L: 125~27 rpm			L: 92~20 rpm			L: 52~10 rpm		
Spindle nose	D1-6			D1-8			A1-11			A2-11		
Spindle bore	56 mm			85 mm			105 mm (opt.)			155 mm (opt.)		
SADDLE												
Longitudinal travel (Z axis)	810 mm	1310 mm	1810 mm	810 mm	1310 mm	1810 mm	810 mm	1310 mm	1810 mm			
Cross slide travel (X axis)	280 mm			350 mm			350 mm					
TAILSTOCK												
Quill travel	170 mm			170 mm			170 mm					
Taper	MT#5			MT#5			MT#5					
MOTOR												
Spindle motor	AC 7.5 HP or 10 HP (opt.)			AC 10 HP or 15 HP (opt.)			AC 10 HP or 15 HP (opt.)					
Ballscrew (Dia. x Pitch)	X: 25 x 5 mm Z: 40 x 10 mm			X: 25 x 5 mm Z: 40 x 10 mm			X: 25 x 5 mm Z: 40 x 10 mm					
Z axis servomotor	6.3 NM			6.3 NM			6.3 NM					
X axis servomotor	6.3 NM			6.3 NM			6.3 NM					
Coolant pump motor	1/6 HP			1/6 HP			1/6 HP					
X, Z FEED												
Z axis rapid travel	7 m/min			7 m/min			7 m/min					
X axis rapid travel	5 m/min			5 m/min			5 m/min					
Machine weight (approx.)	2900 kgs	3200 kgs	3500 kgs	3100 kgs	3400 kgs	3700 kgs	3200 kgs	3500 kgs	3800 kgs			

● L&W Machine Tools, Inc. reserves the right to alter any mechanical specifications without prior notice.

SPECIFICATIONS:

Description / Model	FB-2660	FB-2680	FB-26120	FB-26160	FB-26200	FB-3060	FB-3080	FB-30120	FB-30160	FB-30200	FB-3360	FB-3380	FB-33120	FB-33160	FB-33200			
WORKING CAPACITY																		
Swing over bed	670 mm					770 mm					840 mm							
Center height	335 mm					385 mm					420 mm							
Swing over cross slide	400 mm					500 mm					570 mm							
Distance between center	1600 mm	2100 mm	3100 mm	4100 mm	5100 mm	1600 mm	2100 mm	3100 mm	4100 mm	5100 mm	1600 mm	2100 mm	3100 mm	4100 mm	5100 mm			
Width of bed	450 mm					450 mm					450 mm							
HEADSTOCK																		
Spindle speed	H: 2250~491 rpm			H: 1500~331 rpm			H: 800~176 rpm			H: 1500~331 rpm			H: 800~176 rpm			H: 1500~331 rpm		
	M: 490~126 rpm			M: 330~93 rpm			M: 175~53 rpm			M: 330~93 rpm			M: 175~53 rpm			M: 330~93 rpm		
	L: 125~27 rpm			L: 92~20 rpm			L: 52~10 rpm			L: 92~20 rpm			L: 52~10 rpm			L: 30~6 rpm		
Spindle nose	D1-8			A1-11			A2-11			A1-11			A2-11			A2-15		
Spindle bore	85 mm			105 mm (opt.)			155 mm (opt.)			105 mm			155 mm (opt.)			230 mm (opt.)		
SADDLE																		
Longitudinal travel (Z axis)	1500 mm	2000 mm	3000 mm	4000 mm	5000 mm	1500 mm	2000 mm	3000 mm	4000 mm	5000 mm	1500 mm	2000 mm	3000 mm	4000 mm	5000 mm			
Cross slide travel (X axis)	450 mm					450 mm					450 mm							
TAILSTOCK																		
Quill travel	220 mm					220 mm					220 mm							
Taper	MT#5					MT#5					MT#5							
MOTOR																		
Spindle motor	AC 15 HP or 20 HP (opt.)					AC 15 HP or 20 HP (opt.)					AC 15 HP or 20 HP (opt.)							
Ballscrew (Dia. x Pitch)	X: 28 x 5 mm					X: 28 x 5 mm					X: 28 x 5 mm							
	Z: 50 x 10 mm for FB-2660/FB-2680/FB-26120					Z: 50 x 10 mm for FB-3060/FB-3080/FB-30120					Z: 50 x 10 mm for FB-3360/FB-3380/FB-33120							
	Z: 63 x 12 mm for FB-26160 / FB-26200					Z: 63 x 12 mm for FB-30160 / FB-30200					Z: 63 x 12 mm for FB-33160 / FB-33200							
Z axis servomotor	11.6 NM					11.6 NM					11.6 NM							
X axis servomotor	6.3 NM					6.3 NM					6.3 NM							
Coolant pump motor	1/4 HP					1/4 HP					1/4 HP							
X, Z FEED																		
Z axis rapid travel	7 m/min					7 m/min					7 m/min							
X axis rapid travel	5 m/min					5 m/min					5 m/min							
Machine weight (approx.)	4100 kgs	4600 kgs	5600 kgs	6600 kgs	7600 kgs	4300 kgs	4800 kgs	5800 kgs	6800 kgs	7800 kgs	4500 kgs	5000 kgs	6000 kgs	7000 kgs	8000 kgs			

● L&W Machine Tools, Inc. reserves the right to alter any mechanical specifications without prior notice.

Max. allowable weight of working piece

MODEL	Spindle Bore	Between center (kgs)	With Steady rest (kgs)
FB-18 series	56 mm	570	700
	85 mm	1000	1500
FB-21 series	105 mm	1500	2000
	155 mm	1500	2000
FB-25 series	105 mm	2000	2500
	155 mm	2000	2500
FB-26 series	105 mm	2000	2500
	155 mm	2000	2500
FB-30 series	105 mm	2000	2500
	155 mm	2000	2500
FB-33 series	105 mm	2000	2500
	155 mm	2000	2500
	230 mm	2500	3000
	305 mm	3000	3500

Standard Accessories

- Fagor 8055i CNC control
- Fully enclosure splash guard for distance between centers: 1000/1500/2000/3000mm
Semi-splash guard for distance between centers: 4000 / 5000 mm
- Automatic lubrication system
- Coolant system
- Work light
- Tool kits

Optional Accessories

- Fanuc / Siemens CNC control
- Oil cooler for spindle
- Manual chuck / hydraulic chuck
- Steady rest / Follow rest
- High pressure coolant pump
- Manual / Electrical tool post
- Hydraulic turret
- Hydraulic tailstock
- Live center
- Chip conveyor
- Gap type bed

FB-18 / 21 / 25 Series

	A	B	C	D
40 (D.B.C.:1000mm)	2467	960	1600	1757
60 (D.B.C.:1500mm)	2967	1430	1600	1757
80 (D.B.C.:2000mm)	3467	1680	1600	1757

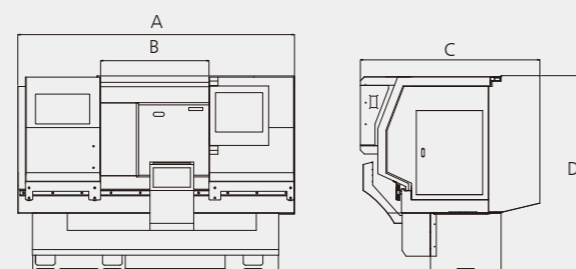

FB-26 / 30 / 33 Series

	A	B	C	D
60 (D.B.C.:1600mm)	3735	1915	2000	2010
80 (D.B.C.:2100mm)	4235	2370	2000	2010
100 (D.B.C.:3100mm)	5235	3052	2000	2010
160 (D.B.C.:4100mm)	6235	4050	2000	2010
200 (D.B.C.:5100mm)	7235	5050	2000	2010

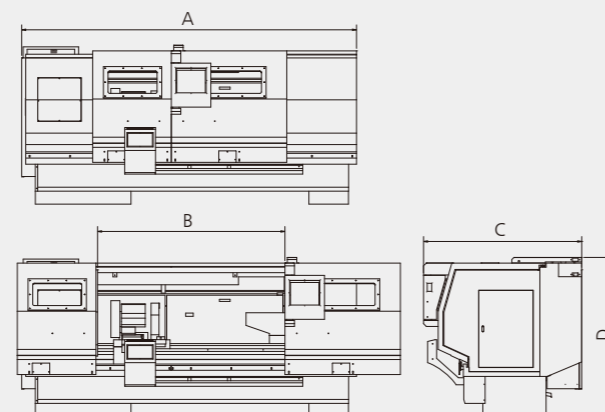

FB-42 / 50 / 51 / 63 SERIES

GENERAL FEATURES



HIGH RIGID BED

The bed and stand are made of one piece Meehanite cast iron which has annealed treatment to eliminate internal residual stress allows for more stability. Resists vibration during cutting.



TAILSTOCK

Rigidly constructed tailstock is able to facilitate making precision turning and drilling. Tailstock quill is hardened and precision ground.



ELECTRICAL CABINET

Electrical cabinet is designed with safety in mind. Easy to maintain and install. The 24V protecting voltage will not harm the operator if receiving a shock.



Power Charts of Inverter Motors

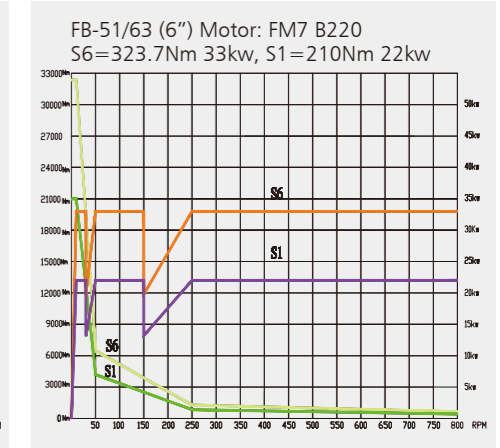
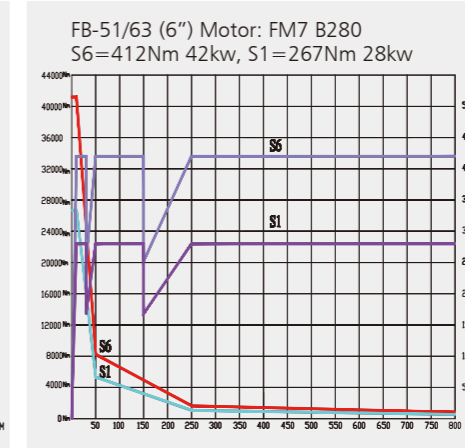
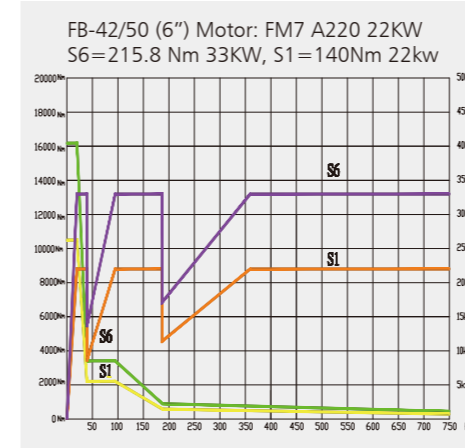

OPTIONS



Steady rest (90 ~ 350mm)



Steady rest (300 ~ 600mm)



Working piece supporter (340 ~ 600mm)



V8 Hydraulic turret



H4 Electrical Tool Post

FB-42~63 series

Extra Large Spindle Bore & Heavy Duty Floor Type Turning Center



Max. allowable weight of working piece

MODEL	Spindle Bore	Chuck + Tailstock	Chuck + Tailstock steady rest
FB-42/50	155 mm	4000	5000
	230 mm	4500	5500
	255 mm	4500	5500
	305 mm	5000	6000
FB-51/63	155 mm	5000	6000
	255 mm	5500	6500
	305 mm	5500	6500
	306 mm	6000	7000
	360 mm	6000	7000

Standard Accessories

1. Fagor 8055i FL TC Controller
2. Half splash guard
3. Chip conveyor
4. Hydraulic tailstock
5. Spindle oil cooler
6. Air condition in power cabinet
7. Lubrication system
8. Center sleeve & center
9. Work light
10. Leveling bolts and pads

Optional Accessories

1. Fanuc / Siemens CNC controller
2. Large spindle bore
3. 3-Jaw Manual / Hydraulic chuck
4. 4-Jaw Manual chuck
5. Manual 4 way tool post
6. Electric servo tool post H4
7. Hydraulic turret
8. Steady / Follow rest
9. C axis & power turret

FB-42/50 Dimensional drawing

UNIT: mm

MODEL	(A)	(B)
FB-42&50/60	4293	3925
FB-42&50/80	4793	4425
FB-42&50/120	5793	5425
FB-42&50/160	6793	6425
FB-42&50/200	7793	7425
FB-42&50/240	8793	8425

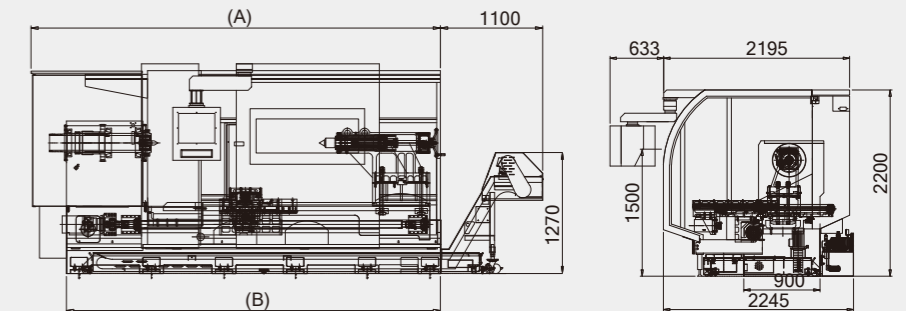

FB-51 Dimensional drawing

UNIT: mm

MODEL	A	B
FB-5160	5440	4440
FB-5180	5940	4940
FB-51120	6940	5940
FB-51160	7940	6940
FB-51200	8940	7940
FB-51240	9940	8940

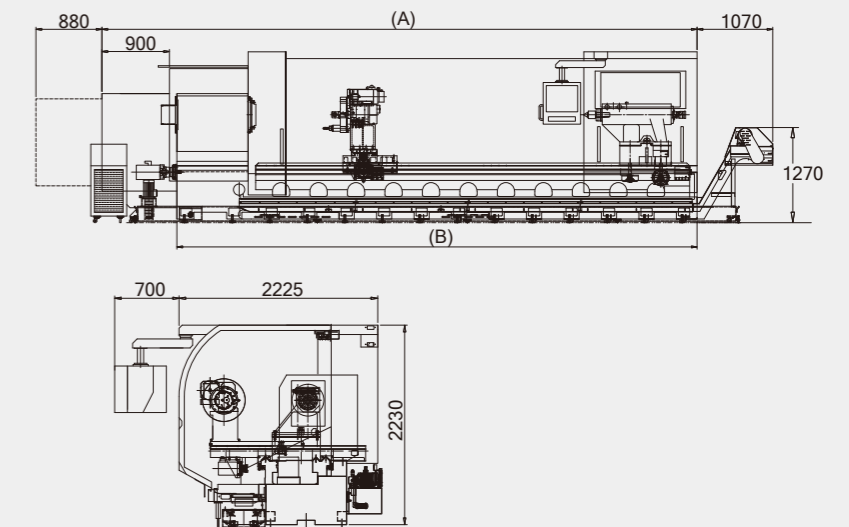

FB-63 Dimensional drawing

UNIT: mm

MODEL	A	B
FB-6360	5440	4440
FB-6380	5940	4940
FB-63120	6940	5940
FB-63160	7940	6940
FB-63200	8940	7940
FB-63240	9940	8940

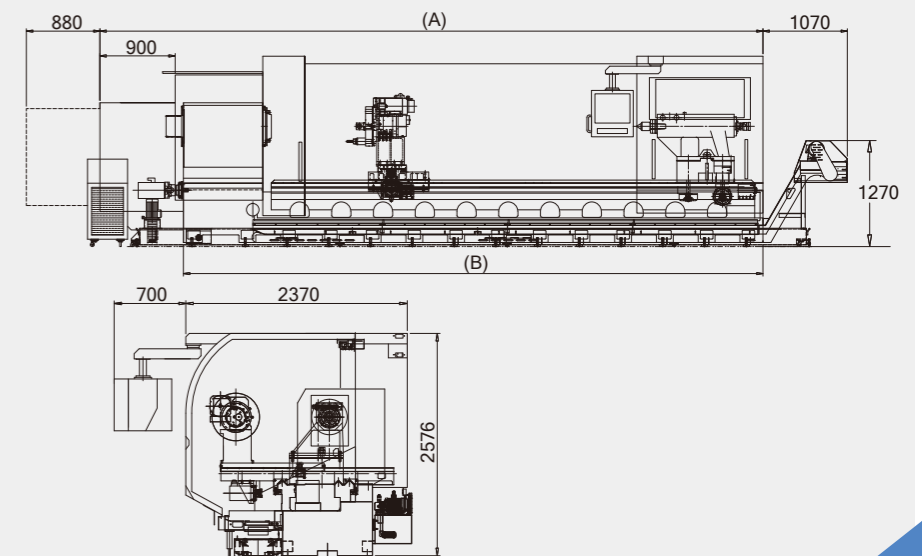

SPECIFICATIONS:

Description / Model	FB-4260	FB-4280	FB-42120	FB-42160	FB-42200	FB-42240	FB-5060	FB-5080	FB-50120	FB-50160	FB-50200	FB-50240
WORKING CAPACITY												
Swing over bed	1070 mm						1270 mm					
Swing over cross slide	744 mm						944 mm					
Distance between center	1700 mm	2200 mm	3200 mm	4200 mm	5200 mm	6200 mm	1700 mm	2200 mm	3200 mm	4200 mm	5200 mm	6200 mm
Suitable 3-jaw hyd. chuck (Opt.)	18"						18"					
Hole through with hyd. chuck	117.5 mm						117.5 mm					
Max. work piece weight (with tailstock)	4000 kg						4000 kg					
Bed width	610 mm						610 mm					
TRAVEL												
X axis	580 mm						680 mm					
Z axis	1500 mm	2000 mm	3000 mm	4000 mm	5000 mm	6000 mm	1500 mm	2000 mm	3000 mm	4000 mm	5000 mm	6000 mm
SPINDLE												
Spindle hole	155 mm	230 mm (Opt)					155 mm	230 mm (Opt)	305 mm (Opt)	410 mm (Opt)		
Spindle nose	A2-11	A2-15					A2-11	A2-15	A2-20	A2-28		
Speed range	H: 151~750	H: 111~560					H: 151~750	H: 111~560	H: 54~270	H: 43~215		
	M: 31~150	M: 21~110					M: 31~150	M: 21~110	M: 11~53	M: 9~42		
	L: 6~30	L: 4~20					L: 6~30	L: 4~20	L: 2~10	L: 1~8		
Suitable 3-jaw scroll chuck size (Opt.)	400 / 500 / 625 mm						400 / 500 / 625 mm					
Servo motor	22 / 33 KW						22 / 33 KW					
TURRET (Opt.)												
Number of tool stations	8						8					
Tool allowance	32 x 32 mm						32 x 32 mm					
Tool shank (Ø)	Ø50 mm						Ø50 mm					
TURRET (Opt.)												
Number of tool stations	4						4					
Tool allowance	40 x 40 mm						40 x 40 mm					
FEED RATE												
X axis rapid traverse	5 M/min						5 M/min					
Z axis rapid traverse	6 M/min		5 M/min		4 M/min		6 M/min		5 M/min		4 M/min	
FEED MOTORS												
X axis power	17.3 Nm						17.3 Nm					
Z axis power	33.6 Nm						33.6 Nm					
BALL SCREW												
X axis	Ø 40 x P8						Ø 40 x P8					
Z axis	Ø 80 X P16						Ø 80 X P16					
TAILSTOCK												
Quill stroke	300 mm						300 mm					
Quill diameter	Ø 165 mm						Ø 165 mm					
Quill inside taper	MT 6						MT 6					
COOLANT												
Pump motor	0.96 (50Hz) / 1.34 (60Hz)						0.96 (50Hz) / 1.34 (60Hz)					
Pump capacity	Min. 35 / Max. 130						Min. 35 / Max. 130					
Pump pressure	4.3 (50Hz) / 6 (60Hz)						4.3 (50Hz) / 6 (60Hz)					
LUBRICATION												
Pump motor	12 W						12 W					
Pump capacity	6 CC/Time						6 CC/Time					
WEIGHT												
Net weight	10000 kg	10800 kg	12400 kg	14000 kg	15600 kg	17200 kg	10600 kg	11400 kg	13000 kg	14600 kg	16200 kg	17800 kg

● L&W Machine Tools, Inc. reserves the right to alter any mechanical specifications without prior notice.

SPECIFICATIONS:

Description / Model	FB-5160	FB-5180	FB-51120	FB-51160	FB-51200	FB-51240	FB-6360	FB-6380	FB-63120	FB-63160	FB-63200	FB-63240
WORKING CAPACITY												
Swing over bed	1300 mm						1600 mm					
Swing over cross slide	900 mm						1200 mm					
Distance between center	1700 mm	2200 mm	3200 mm	4200 mm	5200 mm	6200 mm	1700 mm	2200 mm	3200 mm	4200 mm	5200 mm	6200 mm
Suitable 3-jaw hyd. chuck (Opt.)	18"						18"					
Hole through with hyd. chuck	117.5 mm						117.5 mm					
Max. work piece weight (with tailstock)	5000 kg						5000 kg					
Bed width	770 mm						770 mm					
TRAVEL												
X axis	680 mm						830 mm					
Z axis	1500 mm	2000 mm	3000 mm	4000 mm	5000 mm	6000 mm	1500 mm	2000 mm	3000 mm	4000 mm	5000 mm	6000 mm
SPINDLE												
Spindle hole	155 mm	230 mm (Opt)	305 mm (Opt)	410 mm (Opt)	Large spindle bores are available on request		155 mm	230 mm (Opt)	305 mm (Opt)	410 mm (Opt)	Large spindle bores are available on request	
Spindle nose	A2-11	A2-15	A2-20	A2-28			A2-11	A2-15	A2-20	A2-28		
Speed range	H: 151~750	H: 111~560	H: 54~270	H: 43~215			H: 151~750	H: 111~560	H: 54~270	H: 43~215		
	M: 31~150	M: 21~110	M: 11~53	M: 9~42			M: 31~150	M: 21~110	M: 11~53	M: 9~42		
	L: 6~30	L: 4~20	L: 2~10	L: 1~8	L: 6~30	L: 4~20	L: 2~10	L: 1~8				
Suitable 3-jaw scroll chuck size (Opt.)	400 / 500 / 625 mm						400 / 500 / 625 mm					
Servo motor	22 / 33 KW						22 / 33 KW					
TURRET (Opt.)												
Number of tool stations	8						8					
Tool allowance	32 x 32 mm						32 x 32 mm					
Tool shank (Ø)	Ø50 mm						Ø50 mm					
TURRET (Opt.)												
Number of tool stations	4						4					
Tool allowance	40 x 40 mm						40 x 40 mm					
FEED RATE												
X axis rapid traverse	5 M/min						5 M/min					
Z axis rapid traverse	6 M/min		5 M/min		4 M/min		6 M/min		5 M/min		4 M/min	
FEED MOTORS												
X axis power	23.5 Nm						23.5 Nm					
Z axis power	33.6 Nm						33.6 Nm					
BALL SCREW												
X axis	Ø 40 x P8						Ø 40 x P8					
Z axis	Ø 80 X P16						Ø 80 X P16					
TAILSTOCK												
Quill stroke	300 mm						300 mm					
Quill diameter	Ø 165 mm						Ø 165 mm					
Quill inside taper	MT 6						MT 6					
COOLANT												
Pump motor	1.8 (50Hz) / 2.6 (60Hz)						1.8 (50Hz) / 2.6 (60Hz)					
Pump capacity	Min. 35 / Max. 130						Min. 35 / Max. 130					
Pump pressure	6.2 (50Hz) / 8.3 (60Hz)						6.2 (50Hz) / 8.3 (60Hz)					
LUBRICATION												
Pump motor	12 W						12 W					
Pump capacity	6 CC/Time						6 CC/Time					
WEIGHT												
Net weight	12000 kg	12800 kg	14400 kg	16000 kg	17600 kg	19200 kg	13000 kg	13800 kg	15400 kg	17000 kg	18600 kg	20200 kg

● L&W Machine Tools, Inc. reserves the right to alter any mechanical specifications without prior notice.